

IR spectral characterization of customer blackbody sources: first calibration results

S. Mekhontsev*, M. Noorma, A. Prokhorov and L. Hanssen
Optical Technology Division
National Institute of Standards and Technology
Gaithersburg, Maryland 20899-8442

ABSTRACT

We summarize recent progress in our infrared (IR) spectral radiance metrology effort. In support of customer blackbody characterization, a realization of the spectral radiance scale has been undertaken in the temperature range of 232 °C to 962 °C and spectral range of 2.5 μm to 20 μm . We discuss the scale realization process that includes the use of Sn, Zn, Al and Ag fixed-point blackbodies (BB), as well as the transfer of the spectral radiance scale to transfer standard BBs based on water, Cs and Na heat pipes. Further we discuss the procedures for customer source calibration with several examples of the spectral radiance and emissivity measurements of secondary standard BB sources. For one of the BBs, a substantial deviation of emissivity values from the manufacturer specifications was found. Further plans include expansion of the adopted methodology for temperatures down to 15 °C and building a dedicated facility for spectral characterization of IR radiation sources.

Keywords: infrared, spectral radiance, temperature, fixed-point blackbody, spectral emissivity

1. INTRODUCTION

NIST has well established measurements of spectral radiance in the spectral range below 2.5 μm .¹ But many applications critically depend on spectral radiance of calibration sources in the 3 μm to 5 μm and 8 μm to 14 μm ranges, which until now has not been supported by NIST. Several recent papers have demonstrated that Fourier Transform (FT) spectrometers can perform BB radiation measurements with high accuracy². To study possible approaches, as well as meet particular needs of one of our customers, we used capabilities of a recently constructed facility for direct measurements of spectral directional emissivity of materials³ for spectral characterization of BB sources.

2. INFRARED SPECTRAL RADIANCE SCALE REALIZATION APPROACH AND EXPERIMENTAL SETUP

Our approach, illustrated in Fig. 1 below, is quite common for spectral radiance realization for higher temperatures and the associated visible and near-IR spectral range. The spectral radiance scale is derived from a set of fixed-point BBs, the design and characterization of which were our first tasks. Secondly, we developed transfer standard pyrometers to maintain and interpolate the temperature scale at particular wavelengths. Thirdly, we constructed a spectral comparator consisting of a spectrometer and fore-optics for spectral scale transfer. Finally, we built and characterized a set of variable temperature blackbodies to maintain the radiance scale and interpolate it over the temperature range, as well as provide convenience of use of relatively large and uniform source not requiring neutral gas purge.

* snm@nist.gov; phone 1 301 975-8598; fax 1 301 840-8551, nist.gov

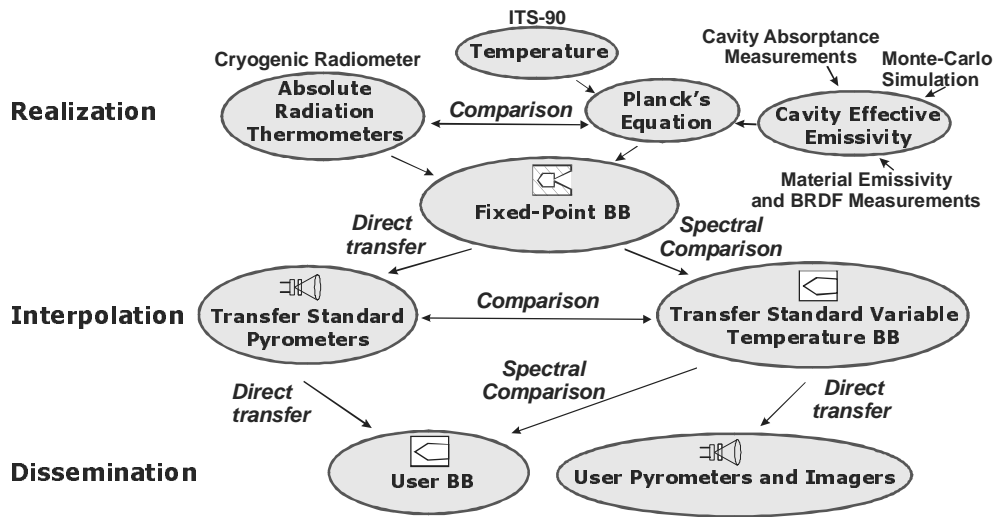

Figure 1: General approach for the spectral radiance scale realization.

As mentioned earlier, for this project we used a facility which is a part of the Fourier Transform Infrared Spectrophotometry Laboratory, dedicated to the characterization of the optical properties of solid materials. The Laboratory covers the infrared spectral range of 1 μm to 100 μm , with particular emphasis on the 2 μm to 20 μm region. It is built around several commercial Fourier transform infrared (FTIR) instruments. The relevant part of the setup is shown in Figs. 2 and 3.

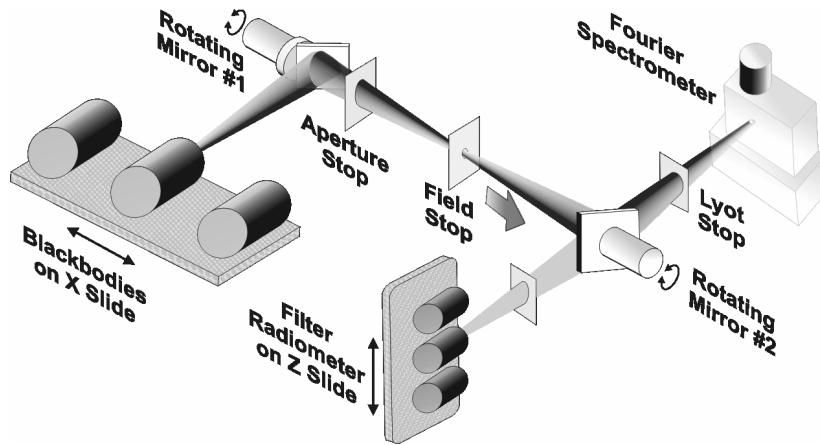

Figure 2: Schematic of the experimental setup.

For the direct measurement of spectral radiance/emissivity of the radiation source, one must compare its' spectral radiance to that of a standard blackbody at a known temperature. The experimental setup consists of a Bomem⁴ DA3 FTIR (Fourier Transform InfraRed) spectrometer and a series of two reference blackbodies. A position is also used for the unknown blackbody under test. A transfer standard pyrometer is included to provide NIST traceability for radiation temperature.

Our high resolution FT spectrometer is not necessarily optimal to the task of blackbody characterization. Nevertheless, we have been able to demonstrate the concept and obtain useful results. For data processing we have employed an algorithm⁵, which involves the spectral comparison of an unknown source with two known sources.

The Bomem FTIR uses interchangeable beam-splitters and detectors to cover a wide spectral interval. For the high temperature portion of this project, from 500 °C to 1000 °C, a MCT (Mercury Cadmium Telluride) and pyroelectric detectors and a KBr (Potassium Bromide) beam-splitter are used to provide spectral coverage from 2.5 μm to 22.2 μm. The blackbodies are installed on a moveable platform that allows the arrangement to be controlled in both x- and z-axes. This allows both the pyrometer and the FTIR to be aligned with the two standard blackbodies and the blackbody under test.

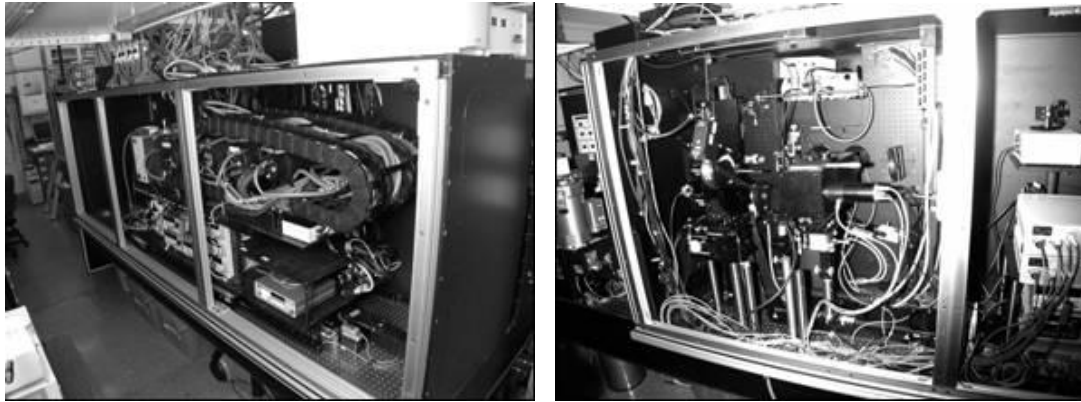

Figure 3: Blackbody (left) and fore-optics / radiometers (right) sides of the facility.

A set of fixed-point BBs, which we have designed, built and characterized, serves as a basis for the spectral radiance scale realization at discrete temperatures. The BBs have 6.5 mm diameter exit apertures and are designed to have high IR emissivity and plateaus of several hours to allow long measurement times. Variable temperature blackbodies based on sodium and cesium heat pipes, are used as transfer standard sources for scale interpolation across the temperature range of interest. The blackbody schematics are shown in Fig. 4; further details of the BB design, results of emissivity modeling and additional evaluations are described elsewhere.^{3,6} Temperatures are derived from ITS-90, although a radiometrically based scale derivation will also be attempted in the near future.

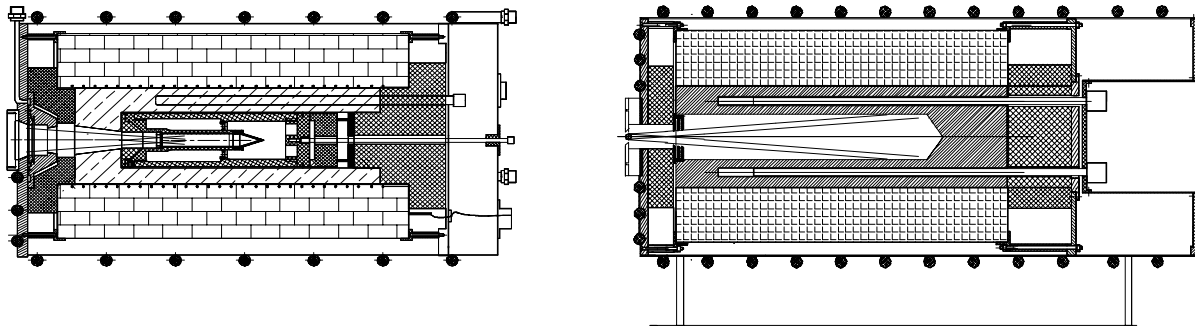

Figure 4: Schematic of fixed-point (left) and variable temperature heat pipe (right) blackbody standards.

Two transfer standard pyrometers, designated *RT900* and *RT1550*, with spectral responsivity centered at 0.9 μm and 1.55 μm, respectively, are used to interpolate the temperature scale between fixed point temperatures, as well as to measure radiance temperature of the customer blackbody. Pyrometer design and evaluation details can be found in another paper presented in this conference⁷.

The spectral comparator contains fore-optics and a spectrometer. The fore-optics, a schematic of which is shown in Fig. 5, contains two off-axis aspherical mirrors and has a low level of out-of-field scatter in the visible and IR. Details of the

optical train design and characterization can be found elsewhere⁸. Size-of-source (SSE) measurements were performed on the interface optics to evaluate the potential errors due to scattering effects. The SSE represents the relative contribution to the measured signal due to radiation from outside the nominal measured area of the source. This can lead to significant measurement error when comparing sources with differing backgrounds. The SSE measurement can be used to evaluate and potentially correct the errors and provide uncertainty contributions. The relatively low value of out-of-field scatter correction amounting to 0.025 % in case of comparing sources with diameters of 7 mm and 38 mm means that for radiance measurements other sources of error will dominate the uncertainty budget. Results for both variable source and central obscuration methods for determining the SSE at several wavelengths are consistent and show acceptable performance.

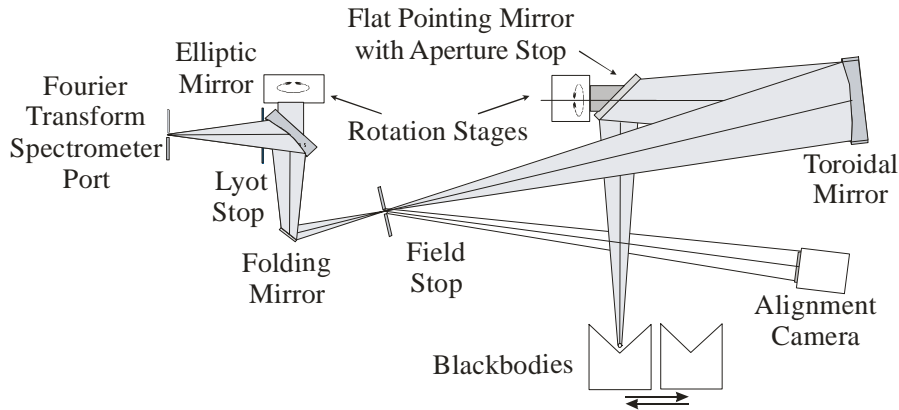

Figure 5: Schematic of the optical interface

The measurement chain sequence that we followed is shown in Fig. 6. In the first stage of the experiment, we performed spectral comparisons of variable temperature heat pipe BBs with a number of fixed-point BBs. In the second stage, a customer BB was spectrally compared with variable temperature blackbodies.

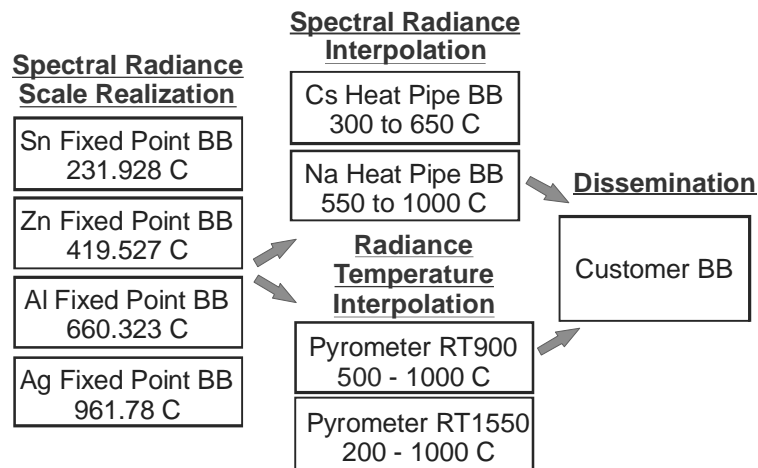

Figure 6: Sequence of measurements

The effective emissivity was always calculated using the radiance temperature at 1.55 μm as the true (reference) temperature. The spectral radiance and the radiance temperature data were also generated during data processing.

3. EXPERIMENTAL RESULTS

3.1 Measurement algorithm

The first step of the blackbody characterization involves obtaining a radiation temperature measurement of both the blackbody under test and the high temperature reference blackbody (“hot reference”). This allows us to deduce the spectral emissivity from knowledge of the measured radiation temperature and the thermodynamic temperature given by the blackbody controller/thermocouple combination. Once the blackbody temperature is stabilized, the radiation temperature at 1.5 μm is measured by aiming the pyrometer at the blackbody apertures of both the hot reference and customer blackbodies. Temperature of the cold reference (a third blackbody at a much lower temperature) is measured by means of contact thermometry.

After the radiation temperature is obtained, the FTIR is used to measure the relative spectral radiance of three blackbodies. In our experiment, “A” represents the reference high temperature blackbody, “B” references the cold reference blackbody at 20 °C, and “C” references the unknown blackbody. The FTIR measurement sequence follows a repeated pattern: A-B-C-B-A-B-C-... . The pattern is repeated and averages are taken to reduce drift effects and to decrease the effect of noise in the detector. A typical experiment may take 8 cycles of A-B-C and 128 scans at each blackbody position. Using the measurement equation (see Fig. 7) the spectral radiance $L_C(\nu)$ is calculated⁵. The radiance temperature measured in the last step is used to deduce the spectral emissivity and the radiation temperature as a function of wavelength.

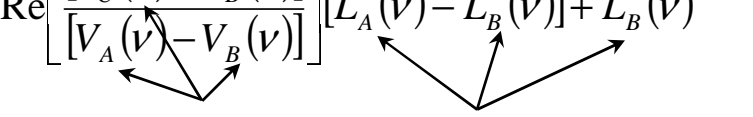
$$L_C(\nu) = \text{Re} \left[\frac{[V_C(\nu) - V_B(\nu)]}{[V_A(\nu) - V_B(\nu)]} \right] [L_A(\nu) - L_B(\nu)] + L_B(\nu)$$

FT measured complex spectra *Products of Planck function & emissivity*

Figure 7: Measurement equation

The data shown below were taken at temperatures that were set identical (within 1-2 degrees C) for both the hot reference blackbody and the unit under test.

3.2 Transfer standard blackbodies characterization

Following the aforementioned measurement sequence and algorithm, we performed spectral characterization of our variable temperature blackbody sources based on Cs and Na heat pipes. The resulting spectra of comparison of (a) Na heat pipe vs. Ag fixed point BB; (b) Cs heat pipe vs. Al fixed point BB, and (c) Cs heat pipe vs. Zn fixed point BB are shown in the Fig. 8 below. For these measurements, the instrument was not purged. Hence, artifacts due to atmospheric absorption lines can be seen in the spectra in the regions of CO₂ and H₂O absorptions. Data in the absorption regions is of variable quality depending on how the much the absorption drifts between measurements. We primarily consider the non-absorbing regions of the spectra in our discussion, including the 3 μm to 4 μm and 8 μm to 14 μm and 15 μm to 16 μm ranges.

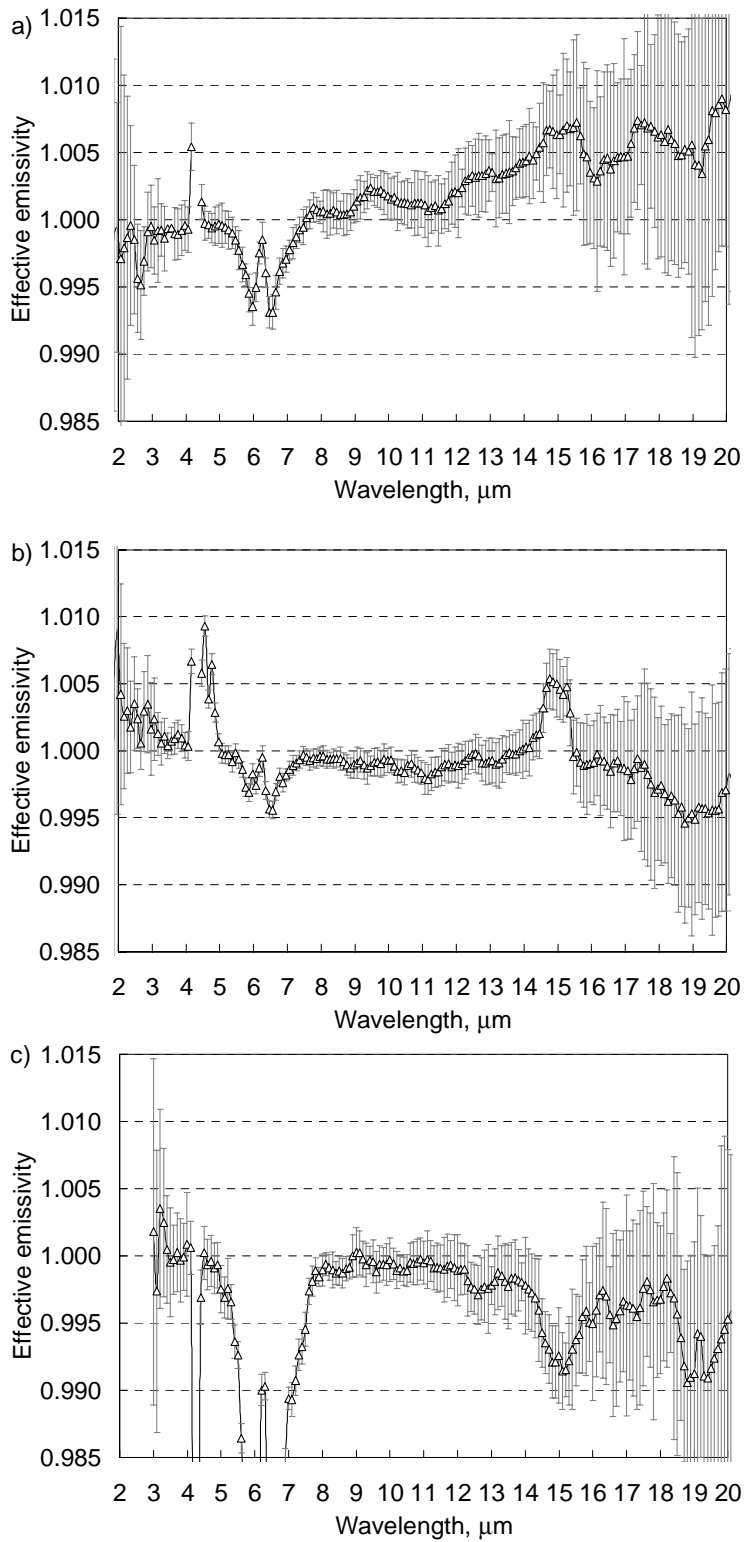

Figure 8: Spectral comparison of a) Na heat pipe vs. Ag fixed point BB; b) Cs heat pipe vs. Al fixed point BB, c) Cs heat pipe vs. Zn fixed point BB. The error bars show the estimated uncertainty ($k=2$).

Table 1: Uncertainty budget of the measurements of spectral emissivity for the secondary standard BB

Temperature, °C	Relative expanded uncertainties ($k=2$) at different wavelength regions, $\times 10^4$		
	3.4-4.2 μm	4.5-4.8 μm	8-14 μm
300	43	29	26
600	21	18	20
800	24	20	18
1000	25	18	22

4. CUSTOMER BLACKBODY CALIBRATIONS

An ideal blackbody is a spatially uniform and temporally stable source with radiance following Planck's law. There are many ways to describe the performance of real-life sources, and before reporting the measurements we need to define our approach. Spectral *radiance* and wavelength dependent *radiance temperature* are the only directly measurable quantities characterizing blackbody output for a particular surface element of the exit port and direction (solid angle). Knowledge of the BB spatial uniformity enables us to reduce the number of variables through averaging. Spectral radiance or wavelength dependent radiance temperature should be measured for a range of set temperatures. The commonly used spectral *emissivity* is a derived unit which makes sense only when calculated and quoted with a clearly defined *reference temperature*, and obtained from the basic measured result of radiance or radiance temperature.

For characterization of customer blackbodies we measure the following:

- horizontal/vertical uniformity scan using a transfer standard pyrometer;
- short term temporal stability measurement with the transfer standard pyrometer;
- radiance temperature measurements at the bb center with the transfer standard pyrometer for each temperature set point of interest;
- spectral radiance measurements at each temperature set point of interest with the FTIR comparator;
- effective emissivity calculation from the measured spectral radiance, using either the set point temperature or pyrometer radiation temperature as the reference.

Calibrated Cs and Na heat pipe blackbodies are used as standards for the measurements of the customer blackbodies for temperatures from 300 °C to 1000 °C in 100 °C steps.

An example of this set of characterization measurements for an industrial high temperature blackbody source is shown in Figure 9. Shown are: the temperature stability (a), spatial uniformity (b), spectral radiance (c), radiance temperature (d) and effective spectral emissivity (e). Radiance temperature measured by the radiation pyrometer at 900 nm is used as a reference for the emissivity calculation.

Examples of effective spectral emissivity results for two customer blackbody designs are shown in Figures 10, 11 and 12. One blackbody has an Inconel cylindro-conical cavity and a 0.5 inch diameter exit port. Radiance temperatures measured at 0.9 μm and 1.55 μm were found to be within 30 mK of each other. The measured spectral emissivity shown in Figure 8 is close to 1 within the uncertainty limits.

A second blackbody has a spherical Inconel cavity with a 0.5 inch diameter exit port. The measurement results for this blackbody, shown in Figures 11 and 12, reveal clear structure in the spectral emissivity. In addition, a systematic difference of 150 mK was found between the radiance temperatures at 0.9 μm and 1.55 μm . The manufacturer specifications include emissivity greater than 0.999. An analysis using our custom sphere modeling software, indicates a possible source for these features in the exit cone temperature non-uniformity combined with a wall coating specularly in the IR.

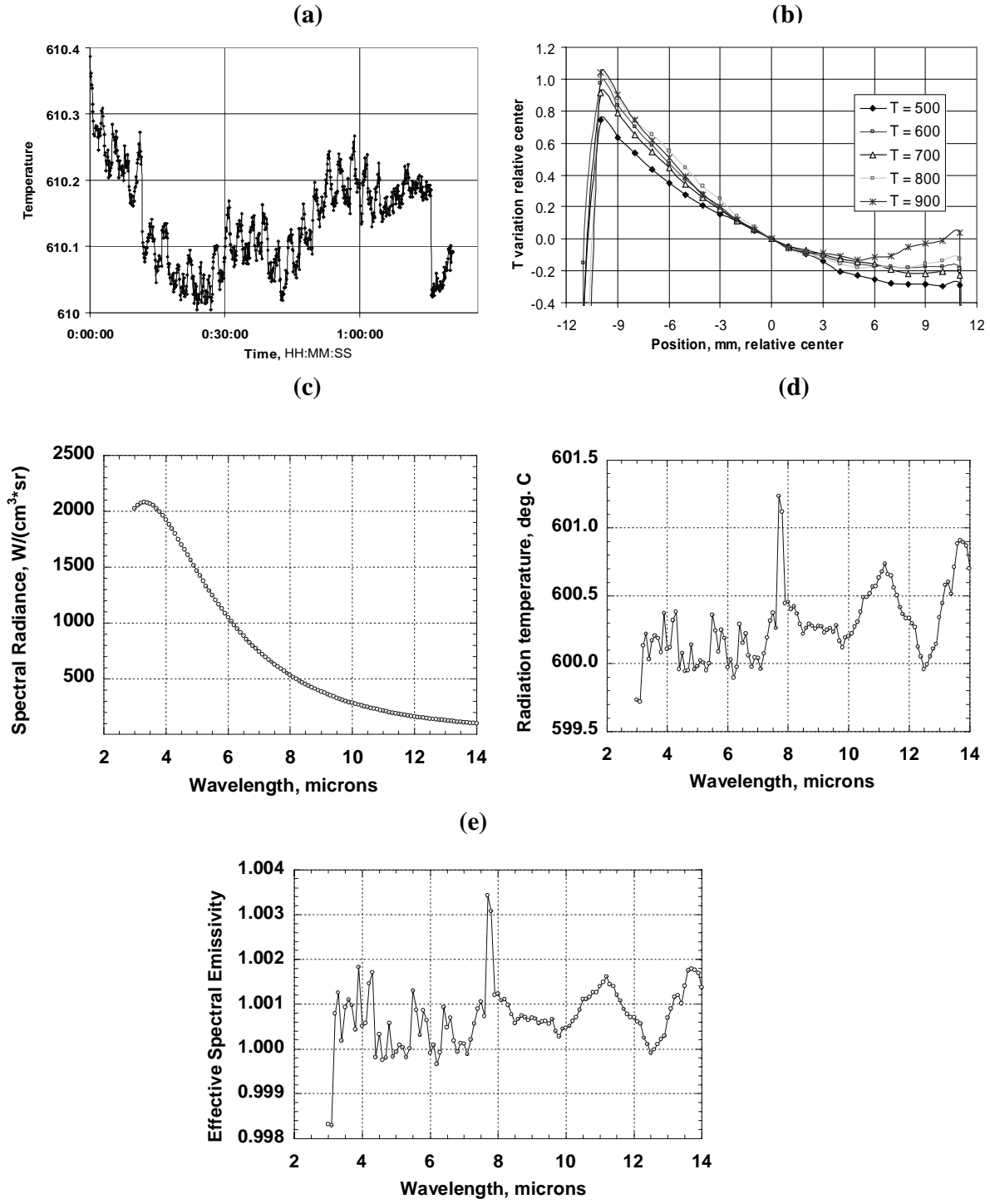

Figure 9: Example of full calibration of an industrial high temperatures blackbody source. Shown are: temperature stability (a), spatial uniformity (b), spectral radiance (c), radiance temperature (d) and effective spectral emissivity (e). Radiance temperature at 0.9 μm is used as the reference for emissivity calculations.

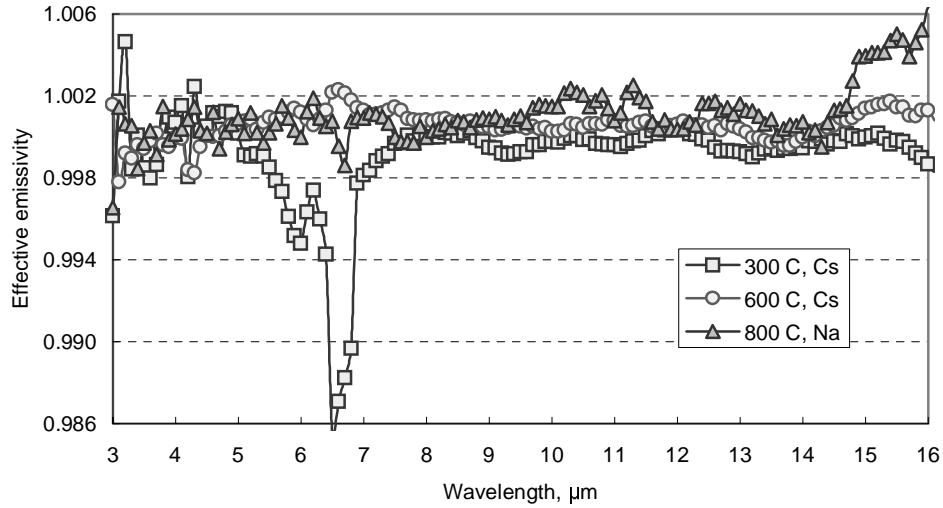

Figure 10: Spectral emissivity of cylindro-conical Inconel cavity. Short measurement time and low temperature stability of BB introduce some additional noise and drift.

The emissivity of one of these had a distinctive pattern evident at all temperatures (600 °C is shown in Fig. 11)

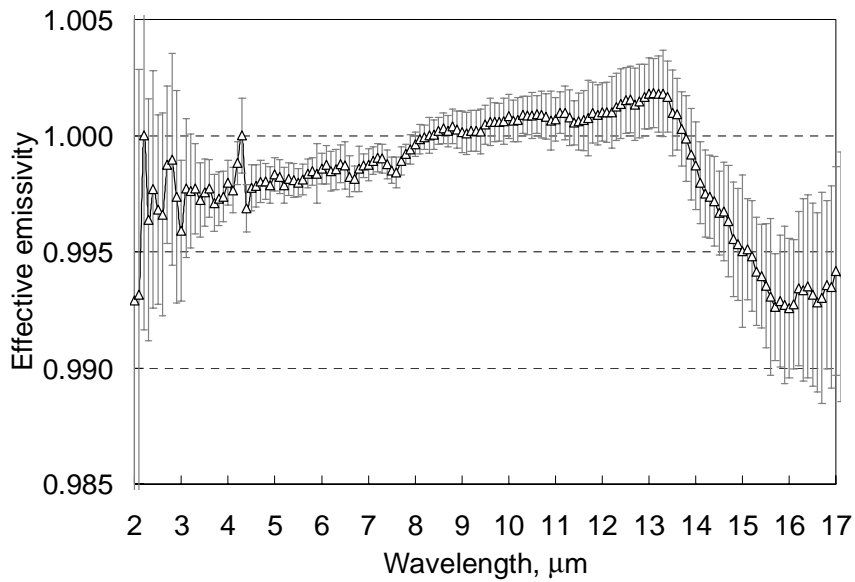

Figure 11. Customer BB calibration result with a distinctive spectral pattern. Error bars show estimated uncertainties (k=2).

Measurements of the second blackbody were made under purge conditions as well as without purge to confirm that the emissivity structure seen was not an artifact due to atmospheric absorption as can be seen in Figure 12.

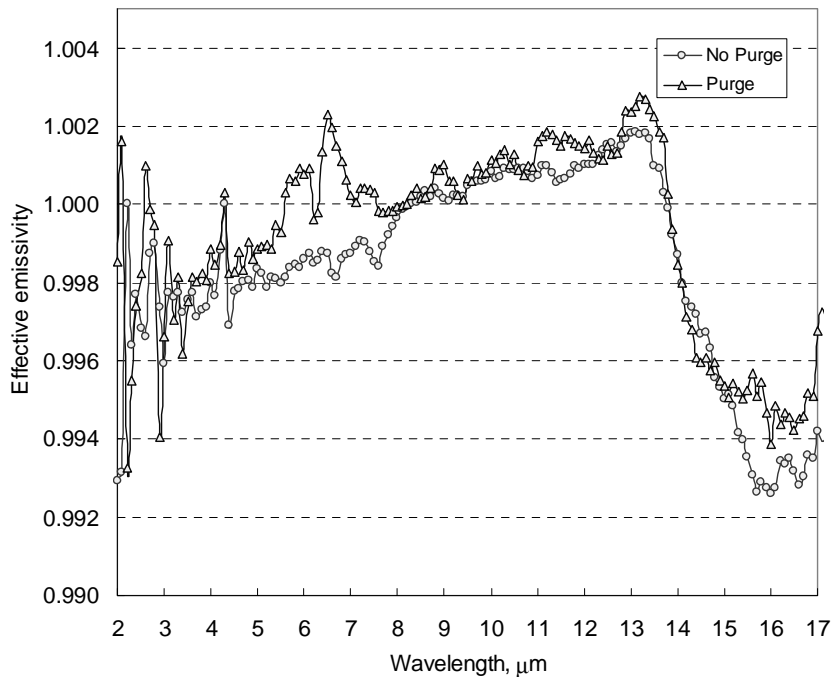

Figure 12. The spectral emissivity measured for a temperature of 600 °C under different atmospheric conditions.

Discussion

A systematic realization of an IR spectral radiance scale has been performed. In the spectral band of 8 μm to 14 μm , the standard deviation of the mean for spectral radiance was typically at the level of 0.1%. In the spectral band from 3 μm to 5 μm , the scatter of the results for most temperatures is substantially larger, possibly relating to use of a wide band pyroelectric detector, and requires further attention. The results show no systematic spectral features for the transfer standard blackbodies but reveal some systematic features for one of the customer BBs. The results are being used to optimize the design of the dedicated AIRI (Advanced Infrared Radiometry and Imaging) facility for spectral characterization of IR sources currently under construction at NIST.

REFERENCES

1. J. H. Walker, R. D. Saunders, and A. T. Hattenburg, *Spectral Radiance Calibrations*, NBS Spec. Publ. 250-1, 1987.
2. A. L. Reesink, N. L. Rowell, and A. G. Steele, "Using Fourier- Transform Blackbody Spectra to Determine Thermodynamic Temperature in the 600 °C to 1000 °C Range," in *Temperature: Its Measurement and Control in Science and Industry*, Volume 7, ed. D.C. Ripple, AIP, 19-24, 2003.
3. L.M. Hanssen, S.N. Mekhontsev, V. B. Khromchenko, "Infrared spectral emissivity characterization facility at NIST," *Proc. SPIE* **5405**, 1-12, 2004.
4. Disclaimer: Certain commercial equipment, instruments, or materials are identified in this paper to specify the experimental procedure adequately. Such identification is not intended to imply recommendation or endorsement by the National Institute of Standards and Technology, nor is it intended to imply that the materials or equipment identified are necessarily the best available for the purpose.
5. H. E. Revercomb, H. Buijs, H. B. Howell, D. D. LaPorte, W. L. Smith, and L. A. Sromovsky, "Radiometric calibration of IR Fourier transform spectrometers: Solution to a problem with the High-Resolution Interferometer Sounder." *AO* **27** (15), 3210-3218, 1988.

6. Mekhontsev, S., Khromchenko, V., Prokhorov, A., Hanssen, L., "Emissivity evaluation of fixed-point blackbodies," Proc. TEMPMEKO 2004, vol. 1, ed. D. Zvizdic, University of Zagreb, pp. 581-586.
7. M. Noorma, S.N. Mekhontsev, V.B. Khromchenko, A. Gura, M. Litorja, and L.M. Hanssen, "Design and characterization of Si and InGaAs pyrometers for NIST radiance temperature scale realization between 200 °C and 962 °C," Thermosense 2006.
8. S.N. Mekhontsev and L.M. Hanssen, "Low scatter optical system for emittance and temperature measurements," in *Temperature: Its Measurement and Control in Science and Industry*, Volume 7, ed. D.C. Ripple, AIP, 693-698, 2003.